

SUN SHINE

ENGLISH VERSION

SPECIFICATIONS

Length over all L.O.A.	: 11.66 m (38' 5")
Hull length	: 11.25m (36' 11")
Length on waterline	: 9.31 m (30' 6")
Midship beam breadth	: 3.45m (12' 7 1/2")
Breadth on waterline	: 3.00m (9' 10")
Draught F/K	: 1.90m (6' 3")
Draught L/K	: 1.24/2.10m (4' 1/4"/6' 10 1/2")
Light weight	: 5750 kgs (12770 lbs)
Ballast weight	: 2200 kgs (4850 lbs)
Fuel capacity	: 85 l (18.7 imp.galls/22.45 US galls)
Fresh water capacity	: 200 l (44 imp.galls/52.84 US galls)
4 separate cabins	
10 berths	
Genoa	: 47m ² (506 sq.ft.)
Mainsail	: 25m ² (269 sq.ft.)
Total sail area	: 75m ² (775 sq.ft.)
Spinnaker	: 102m ² (1098 sq.ft.)
French Merchant Marine Standard N°:	2076
Class	1
Authorized no. of persons	8/3/10
Tonnage	: 12.16 Register tons

DECK FITTINGS

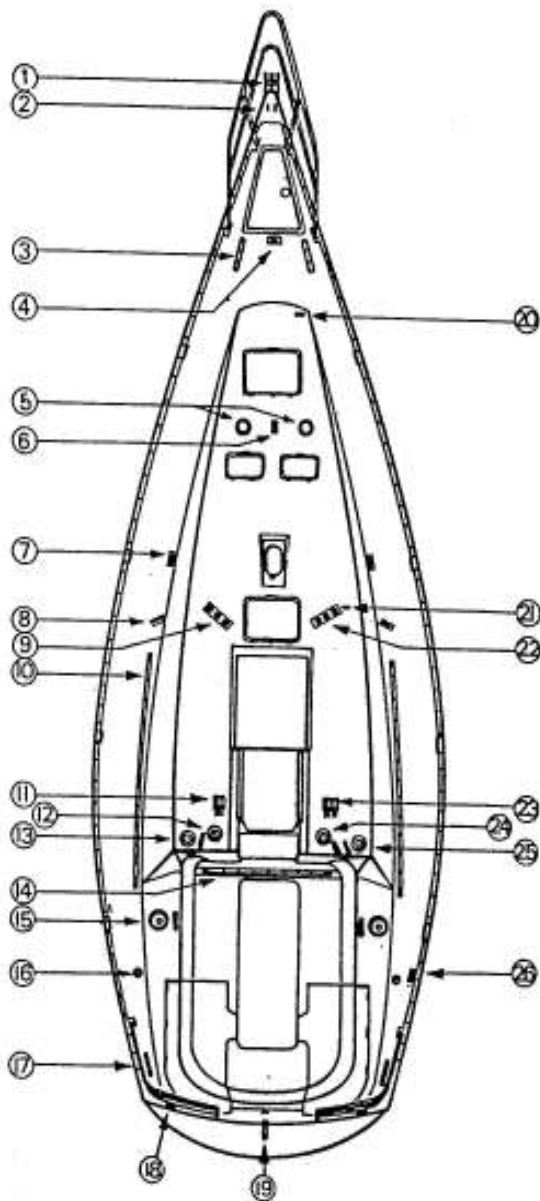

- 1 Stemhead roller
- 2 Genoa bracket
- 3 Forward mooring cleat
- 4 Spinnaker pole downhaul chainplate
- 5 Forward washroom and cabin deck ventilators
- 6 Inner stay chainplate
- 7 Shrouds chainplate
- 8 Aft lower shroud chainplate
- 9 Triple cheek block
- 10 Genoa sheet track
- 11 Jammers: Spinnaker halyard
Mainsail halyard
Boom downhaul
- 12 Winch for 11 above
- 13 Spinnaker sheet winch (optional)
- 14 Mainsheet track
- 15 Genoa winch
- 16 Genoa (return) block
- 17 Aft mooring cleat
- 18 Aft fairlead
- 19 Backstay chainplate
- 20 Spinnaker pole downhaul eyelet
- 21 Triple cheek block
- 22 Jammers: Mainsail clew
Spinnaker halyard
Spinnaker pole topping lift
Spinnaker pole downhaul
- 23 Jammers: Spinnaker halyard
Spinnaker pole topping lift
Spinnaker pole downhaul
- 24 Winch for 23 above
- 25 Spinnaker sheet winch (optional)
- 26 Spinnaker sheet (return) block chainplate

Fixing of the forestay plates at the base

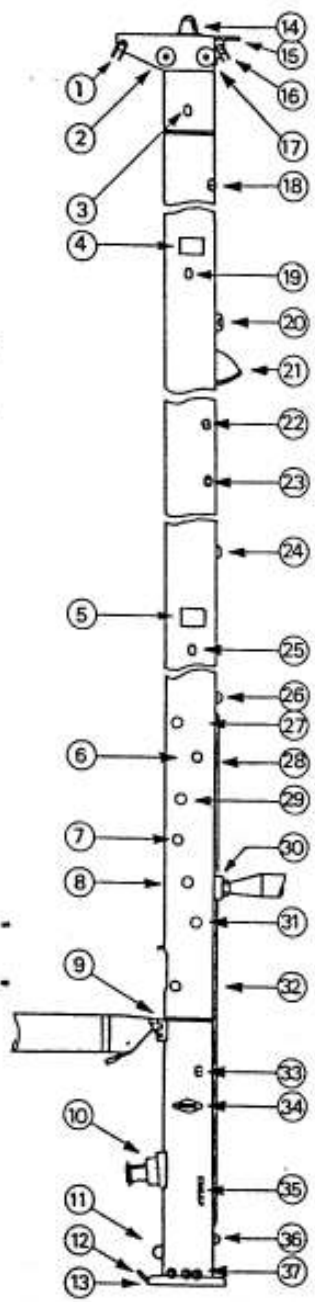

MAST FITTINGS

- 1 Backstay tang
- 2 Mainsail halyard and topping lift sheaves
- 3 Upper shroud coupling
- 4 Spreader fastener (1st level)
- 5 Spreader fastener (2nd level)
- 6 Spinnaker halyard exit (starboard)
- 7 Jib halyard exit (starboard)
- 8 Spinnaker pole no.2 topping lift exit (Portside)
- 9 Gooseneck
- 10 Reef band winch
- 11 Boom downhaul bracket
- 12 Downhaul (return) turning block fastener
- 13 Mast step
- 14 Mast head light
- 15 Spinnaker halyard sheaves
- 16 Stay tang
- 17 Jib halyard sheaves
- 18 Spinnaker halyard exit
- 19 Intermediate coupling
- 20 Head light
- 21 Deck floodlight
- 22 Spinnaker pole no.2 topping lift exit
- 23 Spinnaker pole no.1 topping lift exit
- 24 Inner stay coupling
- 25 Aft lower shroud coupling
- 26 Spinnaker pole track slide eyelet
- 27 Boom topping lift exit (Portside)
- 28 Spinnaker pole track slide
- 29 Mainsail halyard exit (Portside)
- 30 Spinnaker pole track slide traveller
- 31 Jib no.1 halyard exit (Portside)
- 32 Spinnaker pole no.1 topping lift exit (starboard)
- 33 Mainsail halyard exit
- 34 Jockey pole ring
- 35 Mainsail topping lift cleat
- 36 Spinnaker pole track slide eyelet
- 37 Cockpit (return) blocks

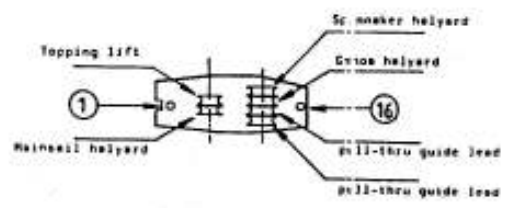

SUN-SHINE: SAILS (TASKER)

(in metres)	LUFF	DROP	LEECH	AREA	LP
1 MAINSAIL	12.19m		4.11m	28.05m ²	
2 LIGHT GENOA	14.40m	13.75m	6.95m	48.40m ²	6.72m
3 INTERMEDIATE	13.90m	12.90m	5.90m	37.60m ²	
4 JIB 1	12.88m	11.35m	5m	27.9m ²	
5 JIB 2	11.88m	9.84m	4.32m	20m ²	
6 STORM JIB	6.25m	4m	3.35m	6.25m ²	2m
7 SPINNAKER	14.06m	4.03m	8.06m	107.7m ²	
8 MEDIUM GENOA	14.2m	13.4m	6.65m	44.5m ²	6.27m
(in feet)	LUFF	DROP	LEECH	AREA	LP
1 MAINSAIL	40'		13'6"	302 sq. ft.	
2 LIGHT GENOA	47'3"	45'1½"	22'10"	521 sq. ft.	22'1½"
3 INTERMEDIATE	45'7"	42'4"	19'4"	405 sq. ft.	
4 JIB 1	42'3"	37'3"	16'5"	300 sq. ft.	
5 JIB 2	38'11½"	32'3¼"	14'2"	215 sq. ft.	
6 STORM JIB	20'6"	13'1½"	11'	67 sq. ft.	6'6½"
7 SPINNAKER	46'1½"	13'2½"	26'5½"	1159 sq. ft.	
8 MEDIUM GENOA	46'7"	43'11¼"	21'10"	479 sq. ft.	20'7"

RIGGING

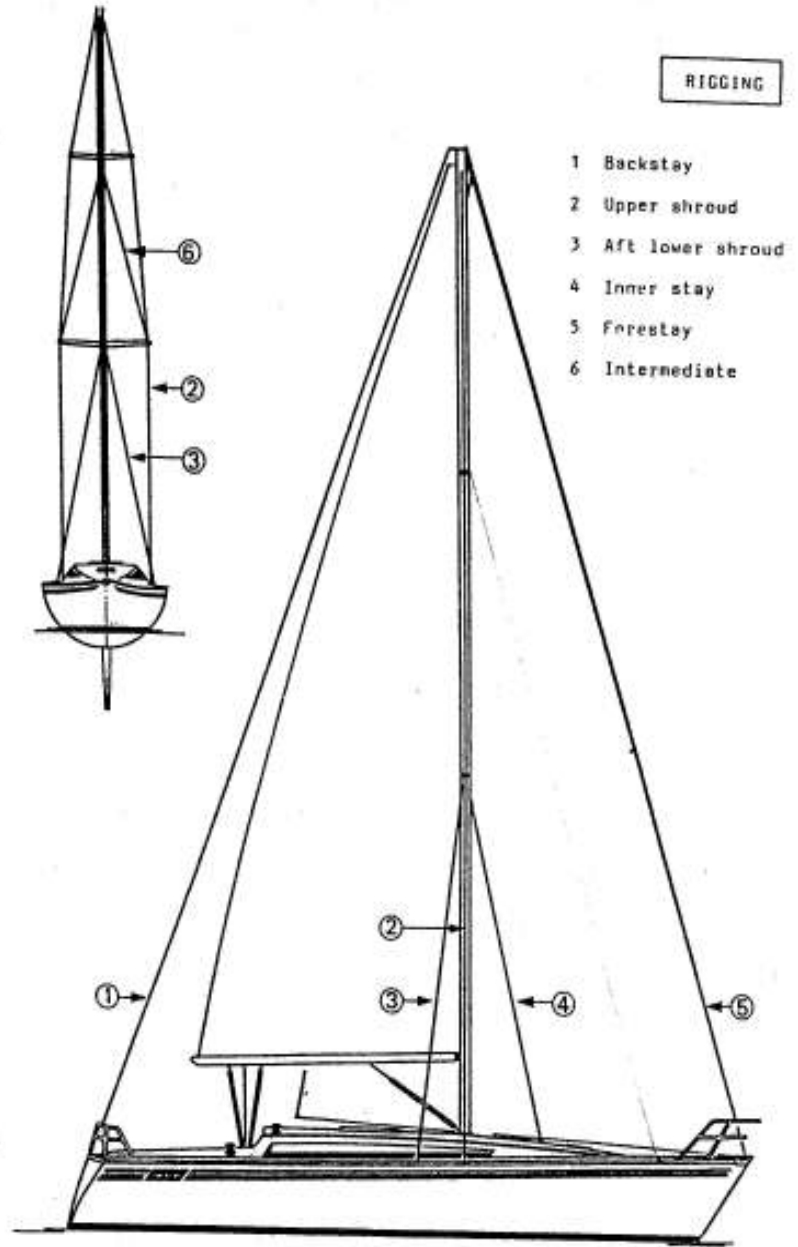

- 1 Backstay
- 2 Upper shroud
- 3 Aft lower shroud
- 4 Inner stay
- 5 Forestay
- 6 Intermediate

HALYARD AND SHEET PLAN

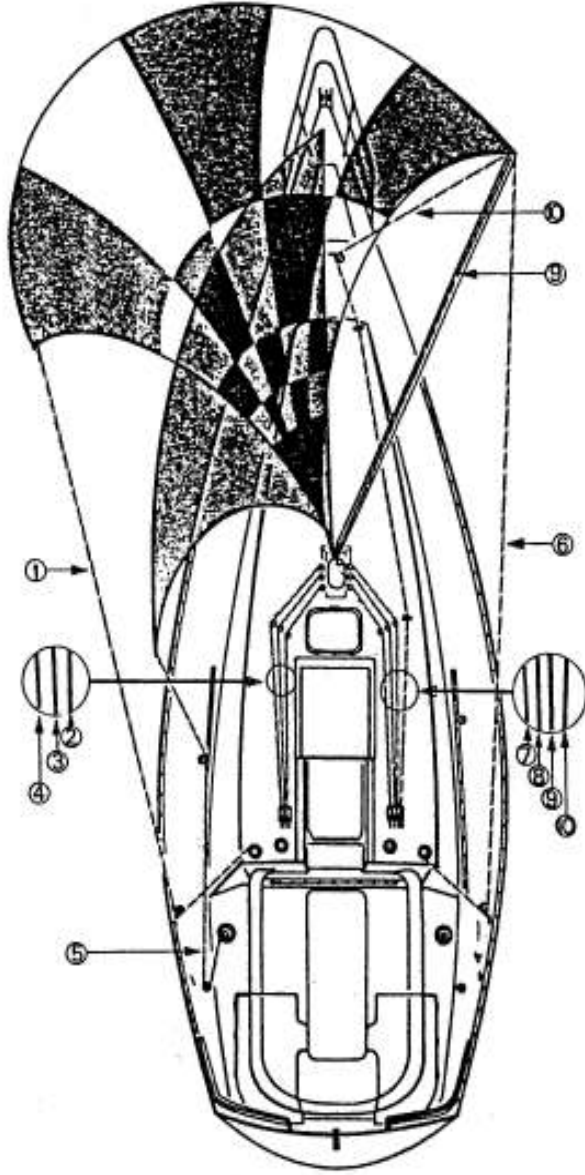

- 1 Spinnaker sheet
- 2 Boom downhaul
- 3 Mainsail halyard
- 4 Jib halyard
- 5 Genna sheet
- 6 Spinnaker guy
- 7 Mainsail clew
- 8 Spinnaker halyard
- 9 Spinnaker pole topping lift
- 10 Spinnaker pole downhaul

BOOM DOWNHAUL AND MAINSHEET

- 1 4 claw outhaul and reef band cam-blockers
- 2 Single fixed-eye block with becket
- 3 Single fixed-eye block
- 4 Boom downhaul vang
- 5 Fixed-eye fiddle block with becket
- 6 Preventer - steel cable
- 7 Cam blockers
- 8/9 Single fixed-eye block
- 10 Mainsheet tackle
- 11 Single fixed-eye block
- 12 Fixed-eye fiddle block with becket and blocker

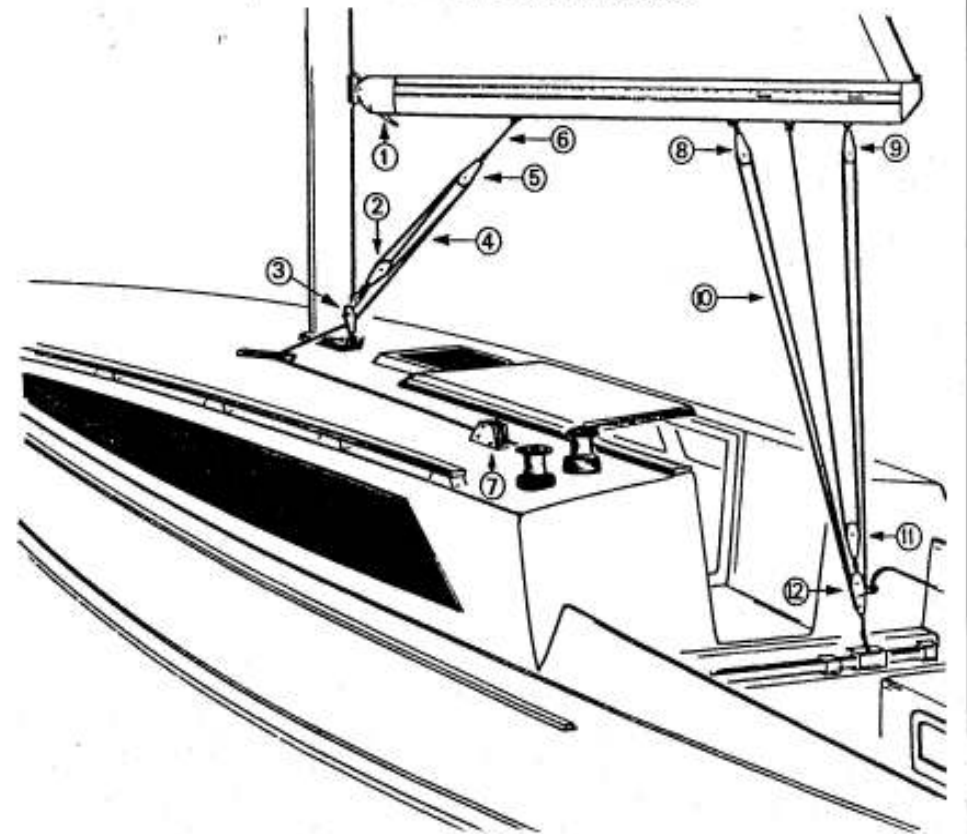

WATER FUEL SYSTEMS TEAM VERSION

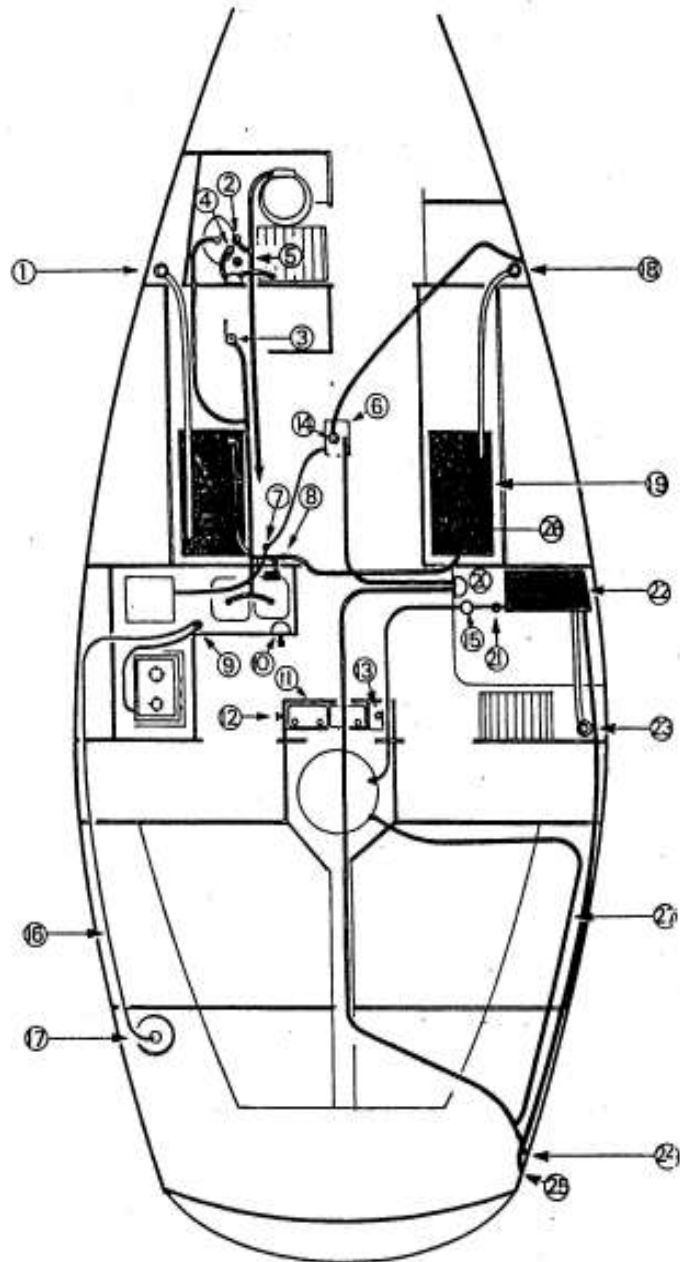

- 1 Fresh water fill cover (Portside)
- 2 Seawater intake cock (Galley & WC flush supply)
- 3 Waste water drain cock (sinks and washbasins)
- 4 Shower drain cock (pump below washroom washbasin unit)
- 5 WC drain cock
- 6 Water trap with electric pump filter and manual pump facility
- 7 Icebox drain cock
- 8 Port and starboard water tanks supply cock (access below floor)
- 9 Gas shut-off cock (access below sink cupboard unit)
- 10 Sink water foot pump (see following page for guidance)
- 11 Battery tray (2 x 70Ah)
- 12 Circuit breakers (from bottom to top: engine circuit breaker - earth circuit breaker - inboard circuit breaker) + electric bilge pump switch
- 13 Engine cooling water intake cock
- 14 Electric bilge pump
- 15 Fuel filter decanter
- 16 Gas supply pipe
- 17 3-kg gas canister (access in port side locker)
- 18 Fresh water fill cover (starboard)
- 19 Water tank (100 l) (22 imp.galls/26.42 US galls)
- 20 Manual bilge pump (access beneath chart lectern)
- 21 Fuel shut-off cock (access beneath chart lectern)
- 22 Fuel tank (85 l) (18.7 imp.galls/22.45 US galls)
- 23 Fuel fill cover
- 24 Bilge pump outlets
- 25 Fuel tank air intake
- 26 Finger-holes behind saloon back cushions give access for checking of water tanks
- 27 Exhaust non-return bend pipe

N.B: A small aperture can be found under the second step of the companionway descent for the introduction of an extinguisher.

GALLEY WATER SYSTEM

TEAM VERSION

- 1 Fresh and sea water by foot pump - tap
- 2 Fresh water by electric unit - tap
- 3 Washroom supply pipe
- 4 Sink sea water supply pipe
- 5 Port water tank inflow pipe
- 6/7 Fresh and sea water supply cocks
- 8 Electric water unit
- 9 Starboard water tank shut-off cock
- 10 Starboard water tank inflow pipe
- 11 Fresh and sea water foot pump

Use: In normal use the electric unit feeds fresh water to cock 2, and the foot pump sea water to cock 1 (cock 6 in "closed" position, cock 7 in "open" position)

Where electric unit malfunctions (or for battery conservation) the foot pump can also be used for fresh water (cock 6 in "open" position, cock 7 in "closed" position)

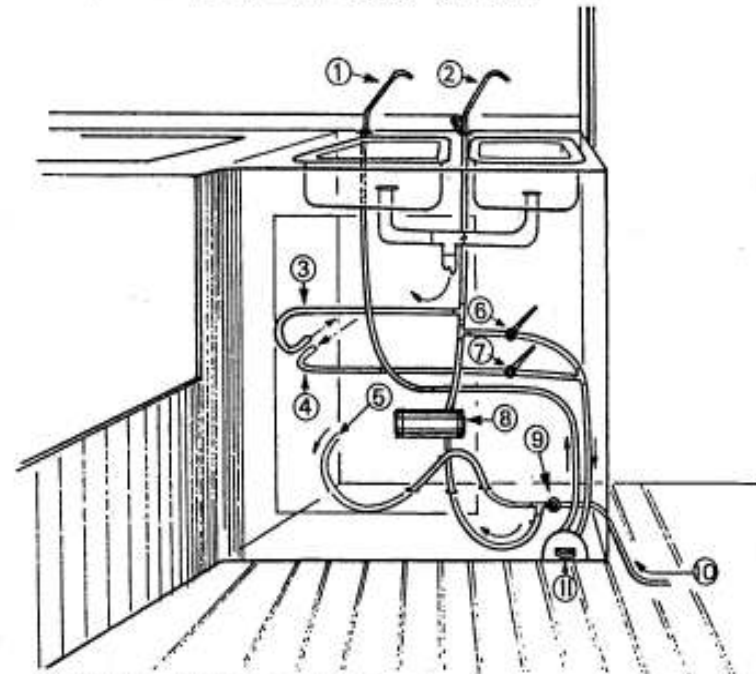

IMPORTANT: Beware of polluted water supply when using sea water pump system

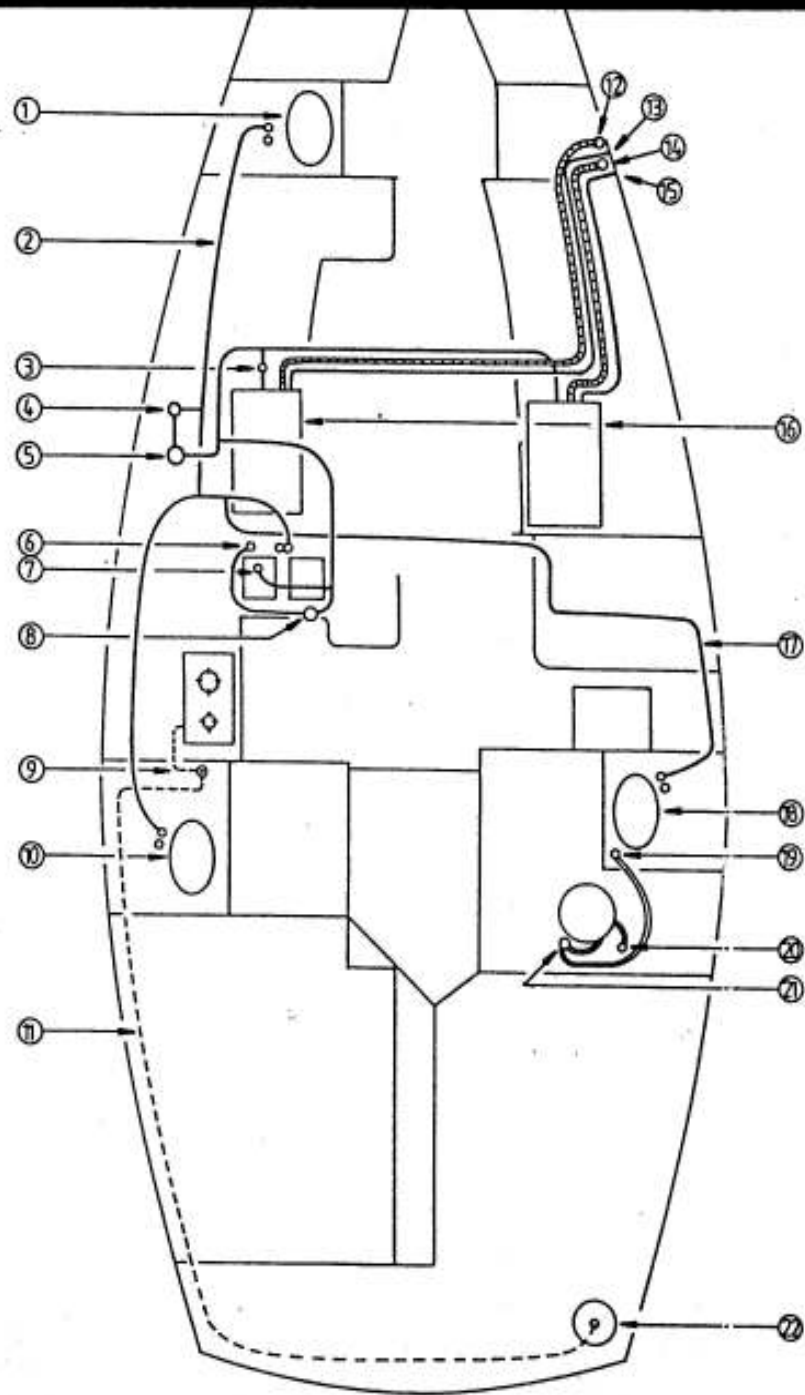

WATER SYSTEM
GAS SYSTEM

OWNER'S VERSION

- 1 Forward cabin washbasin
- 2 Forward cabin water supply
- 3 Water system distribution cock
- 4 Expansion chamber
- 5 Water pressure pump unit
- 6 Tap on foot-pump (Fresh water and sea-water)
- 7 Sea-water intake cock
- 8 Galley foot-pump (fresh water and sea-water)
- 9 Gas system shut-off cock (situated in hanging locker)
- 10 Aft cabin washbasin
- 11 Gas system
- 12 Port tank deck filler cover
- 13 Breather to above tank
- 14 Starboard tank deck filler cover
- 15 Breather to above tank
- 16 Port and starboard tanks (2x100 l/2x.../...)
- 17 Washroom/head supply
- 18 Washroom/head washbasin
- 19 WC drainage cock
- 20 WC flush water intake
- 21 WC pump
- 22 Gas canister

IMPORTANT : Beware of polluted water in the case of using the sea-water pumping system to the galley sink.

RUDDER CONTROL

- 1 Wheel
- 2 Emergency back-up tiller
- 3 Rudder stock
- 4 Steering quadrant
- 5 Steering wires adjustment
- 6 Blade
- 7 Steering column
- 8 Wheel stops
- 9 Transmission pulleys
- 10 Steering wires
- 11 Stock seals
- 12 Rudder tube
- 13 Gudgeon

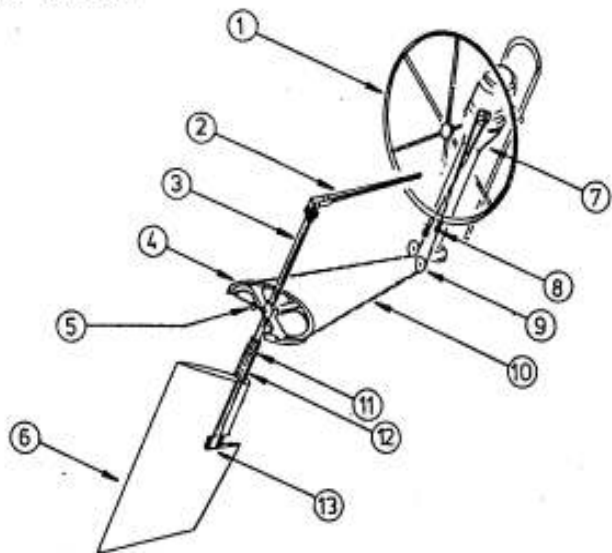

DROP KEEL MECHANISM

- 1 Drop keel housing cover
- 2 Drop keel housing
- 3 Raising cable (48mm = 0.31 of an inch)
- 4 Raising winch
- 5 Drop keel release valve with hose tail (access under floor)
- 6 Raising arm
- 7 Drop keel axle
- 8 Lateral centring studs
- 9 Drop keel stop
- 10 Drop keel

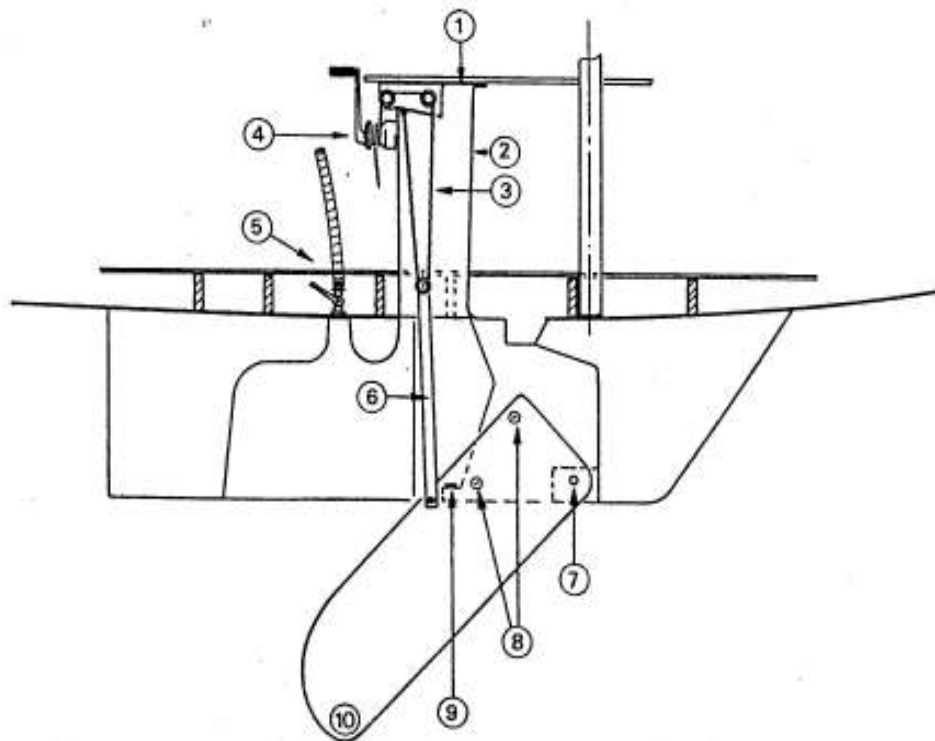

IMPORTANT: When not in use, it is recommended that you do not excessively block the drop keel in a high position, and thus create a certain amount of play in the drop keel.

BEFORE PUTTING THE BOAT INTO THE WATER

- Provide for the eventual installation of the echo-sounder and speedometer sounds if your boat is to be fitted with these devices.
- Check the engine and gear-box oil levels (as per your engine maintenance manual). The engine cooling-water drain cocks must be in the closed position.
- The sealing, by means of a sealant, of all optional accessories is essential.
- Push the speedometer sound into its housing (may be damaged by lifting slings).
- On shaft-line engines, check that the anode situated at the end of the shaft is indeed in place and check the tightness of the nut as well as the lock-washer.
- All seacocks (intake and discharge) must be in the closed position (sinks, washbasins, WC, engine).
- Place mooring lines fore and aft as well as fenders.
- Check that on lifting no sling comes into contact with any equipment (echo-sounder, speedometer, prop shaft...).

It is worth noting that marking the position of the slings (tape on the wash-strake) on lifting saves time on later lifting operations.

MASTING

- Before masting, lubricate all turnbuckles using a "marine use" lubricant (silicone grease).
- Avoid masting your boat with antennae fitted.
- On masting check the blocking and position of the spreaders (always above the horizontal) and see to it that the mast base is totally supported on the mast step.
- Protect the spreader tips.
- When fitting the standing rigging, be careful not to get cables similar in length mixed up.
- Tension the rigging making sure that the mast throat remains rectilinear.
- The optimum mast adjustment is effected during the boat's first trip under sail.
- Once the adjustment is completed, block the bottlescrews for good, protect the split-pins and the bolts using sticky tape.

MASTING (cont'd)

- After the first few trips under sail, it is a good idea to check the adjustment as new cables may undergo slight lengthening.
- In port it is advisable to release the tension on the backstay.

Rigging version:

- Mast makers strongly recommend the use of running backstays when these are fitted.
- The use of running backstays is favourable to the smooth progress of the boat.
- The warranty will be invalidated by incorrect use but remains valid where there is an error in manufacture.

ON PUTTING THE BOAT INTO THE WATER

- Check the speedometer and echo-sounder sounds are watertight.
- Open the seacocks and make sure they are watertight with the hull and with the corresponding hosepipe.
- Also check the stuffing-box for leakage (refer to paragraph "STUFFING-BOX" under heading "MECHANICS").
- BEFORE STARTING THE ENGINE:

Open the fuel cock.

Open the engine cooling-system cock.

Engage the electrical circuit by means of the battery cut-out.

Before starting the engine, disengage the gear so as to obtain the idle position (tick over).

For engine starting procedure consult the engine maintenance manual.

As the engine is turning over, check the cooling system is functioning correctly, then let the engine warm up for a few minutes, after which time you should put FORWARD and REVERSE into gear one after the other whilst at idle speed.

Check that the cooling system water is coming out of the exhaust if this is not the case, stop the engine immediately and check the water system (cock, blocked filter).

SEACOCKS:

As a general rule it is recommended that you close "thru-hull fitting" seacocks after use.

LIFE-LINES:

The life-lines are tensioned between the pulpits by means of a tensioning screw/nipper.

BEACHING:

Make quite certain of the nature of the bottom before beaching (silty bed, rocky floor) and of the weather forecast!...

MECHANICS

ENGINE:

Consult the instructions supplied in the boat. It is VITAL that you read these CAREFULLY, they will give you a detailed explanation of how the engine works and of all those operations which will permit correct use and thus keep it in good running order.

ANODE:

From time to time check the corrosion of the anode situated at the end of the prop shaft and change it if necessary. It is advisable to add an anode to the shaft between the P-bracket and the hull approximately 10cm (4") ahead of the P-bracket (obligatory on a folding prop).

PROPELLER:

The propeller supplied as standard with your boat is the result of exhaustive tests carried out by Jeanneau in close collaboration with the engine manufacturer.

DO NOT CHANGE THE PROPELLER WITHOUT FIRST CONSULTING A SPECIALIST

FUEL FILTER:

To clean the fuel filter:

- . completely unscrew the lower screw on the bowl;
- . remove;
- . empty and clean the bowl;
- . change the filter (if necessary);
- . reassemble the unit.

To BLEED, unscrew the screw provided for this purpose.

STUFFING-BOX:

As the shaft turns, water should drip from the stuffing-box approximately once every five to ten seconds and there should be practically no drip when the shaft is stopped (slight seepage can be allowed).

To adjust:

- tighten or loosen the two adjuster-nuts*;
- make sure the tightening flange remains parallel to the body of the stuffing-box;
- From time to time check the condition of the hose connection.

BEWARE!! Never overtighten the stuffing-box as this will very rapidly deteriorate the packing inside.

AT THE END OF THE SEASON, Take the tightening flange completely out and check the condition of the packing. If the latter is very dry or if the flange comes up against the body of the stuffing-box, change it or top it up.

BEWARE! This should only be carried out when the boat is OUT OF THE WATER.

MECHANICS (cont'd)

STUFFING-BOX, turning-gasket model (ERCEM):

- . **IMPORTANT SAFETY NOTE:** The gland must be checked without fail once a year by an approved specialist.
- . Do not forget, following the fitting of the ERCEM gasket, to let water penetrate the interior of the gland by slightly drawing it.

ENGINE OPERATION:

BEWARE: Never cut the electrical circuit while the engine is running, such action would cause immediate and irreparable damage to the charging equipment.

If your boat is fitted with a diesel engine with a stop-pull knob, it is essential to use this before cutting the circuit with the ignition-key.

Diesel: Do not wait for the fuel level to drop to near empty before filling up; this may cause the fuel system to fail.

Petrol: It is important to operate the bilge blower before starting up the engine, so as to evacuate any build up of fuel vapour.

Throttle/gear lever controls:

To release the gear mechanism:

- . put the lever into neutral and press the red button.
- . in this position only the throttle is operational.

Engine compartment fire:

Half-way down the companionway steps (on the engine compartment cover) is a hole into which the nozzle of a fire extinguisher can be introduced in the case of fire in the engine compartment.

Exhaust:

Make a yearly inspection of the exhaust system and replace if necessary.

Fuel system:

From time to time check the seals and hose connections of the fuel system.

STEERING WHEEL:

Make a regular check of the tension of the steering wires.

MANUFACTURER'S IDENTIFICATION PLATE:

The boatbuilder's ID plate is affixed to the boat and must include the following information:

- . Year of manufacture
- . Boat type
- . Serial number
- . Maximum number of persons allowed aboard
- . French Merchant Marine Approval Number
- . Navigation class
- . Maximum power

INTERIOR FITTINGS

WC:

When not in service it is advisable to close the cocks.

Instructions for use:

Make sure that the supply and discharge cocks (inflow/outflow) are open.

To empty bowl, put the pump handle into the "horizontal" position (FLUSH) and work the pump.

To pump dry the bowl, put this handle back to the "vertical" position (DRY) and work the pump.

Shut cocks after each use and above all remember to do this when there is no-one aboard.

- When the boat is to be put up for the winter, remove the drain plug situated in the base and work the pump having put the handle into the "horizontal" position.

It is recommended if sea-water has been used to rinse out the WC using fresh water by working the flush vigorously to ensure good working order for the season to follow.

DO NOT USE EITHER ANTI-FREEZE NOR CHEMICAL PRODUCTS

CUSHIONS AND MATTRESSES:

Take advantage of any fine weather to air the settee seating and backrest cushions as well as the mattresses.

GALLEY / HEAD:

If your boat is fitted with fibreglass sanitary fittings, these can be cleaned with a sponge soaked in water and liquid soap.

Scouring powders or abrasive brushes and sponges should not be used.

ELECTRICAL CIRCUIT:

Do not place any electronic instruments or indicators (repeater compass) less than 1m30 (4'11") from the radio equipment's speakers.

Batteries:

- Check the water level (except for sealed batteries) and top up if need be with distilled water.
- Keep the battery terminals clean and well-maintained.
- Spray the connections with an insulating product so as to protect them from humidity.

GAS SYSTEM:

- Should the gas-bottle be disconnected, screw the cap back onto the thread of the regulator to prevent any corrosion.
- Replace the hosepipe at the given expiry date.

WATER-TANKS:

The water tanks can be sterilized by dropping in cionazone tablets (available from chemist's and pharmacies).

In extended non-use, purify tanks and hoses (acetic acid, white vinegar).

Inspection traps are fitted into the stainless steel tanks and thus permit the cleaning of the inside.

MAINTENANCE AND OUT-OF-SEASON STORAGE

MAINTENANCE

Moving and mechanical parts must be greased on a regular basis:

- Engine-stop pull-knob, sliding bolts, hinges, locks.
- Gear-box control-lever box

This greasing is to be effected using products specially intended for use in the marine environment (White Teflon grease).

Strip down and clean fuel separator from time to time.

For the mechanics, refer to the maker's handbook and consult your approved brand dealer or stockist.

MAINTENANCE OF STAINLESS STEEL AND BRASS:

To be maintained on a regular basis.

Buff up stainless steel and brass articles using a suitable product ("Minox" in France) should these show signs of surface oxydation.

Rinse deck-mounted stainless steel fittings with fresh water at the end of each season.

WINCHES:

The maintenance of winches must be carried out regularly.

Here are a few hints which should allow you to keep your winches in good working order:

- 2 or 3 times a season dismantle the drums, clean and grease
- at the end of the season, totally strip down, clean with petrol and then grease.

We recommend the use of a white grease with Teflon.

This grease is peculiar in that it reduces friction and helps combat corrosion. It also has the advantage of being non-messy, non-toxic and bio-degradable.

SAILS:

- Avoid letting the sails beat for too long when drying out;
- The initial trips should be effected in medium wind so as to allow the cloth to settle into place.
- Effect an end-of-season fresh-water rinse.

So as to avoid damage to the sails and sheets, do not hesitate to "bandage up" (by means of adhesive tape) any part which might cause a tear or damage (split-pins, bolts, pins, bottle screws etc...)

RIGGING:

Make an occasional check of the tension of the rigging as well as a check of the blocking of the lock-nuts and shaft split-pins.

MAINTENANCE AND OUT-OF-SEASON STORAGE (cont'd)

HULL:

A frequent cleaning of hull and deck should be observed using (non-abrasive) cleaning agents (such as "Mia" in France) and fresh water.

Should yellow staining appear, this can be removed easily with a cleaner your dealer should be able to supply (such as "Super Decap" in France). BE CAREFUL TO RINSE WELL using water and a brush (a maximum of ten minutes after the application of the product).

For the hull a yearly antifouling will avoid tiresome and time consuming hull cleaning (rub hull down lightly before application).

While on this subject, a necessary reminder: any rubbing down of the hull or priming before antifouling attacks your gel-coat and undermines its reliability. We thus advise a very light rub-down.

The gel-coat (exterior finish to GRP) can be relied on to keep its appearance.

Against difficult staining on the waterline, muriatic acid can be used. After allowing the acid to work for ten minutes rinse off thoroughly.

Polishing pastes can keep your boat looking as new.

For repairs, refer to attached notes.

Should an immediate and lasting problem arise, we advise you consult your dealer or the JEANNEAU company directly.

Avoid using a high-pressure water cleaner above 40°, maximum pressure:

OUT-OF-SEASON STORAGE

For an extended out-of-season storage, particular care must be taken of the entire boat:

• Rinse with fresh water.

• Oil and grease all metal parts.

If the boat is to remain afloat, close all sea-cocks and protect all those parts which might rub or scrape...

Raise the speedometer sound.

If the boat is fitted with a stuffing-box, it is as well to slightly tighten it so as to render it perfectly watertight; do not fail to readjust it before the next trip out.

• Drain water systems (beware of freezing!).

Should you be leaving your boat over a period of several months the best procedure is to block off all air inlets and to install a dehumidifier in the saloon whilst leaving cabin, hanging and other locker, ice-box and other doors open. It is also a good idea to stand all mattresses and cushions on their sides.

CARE OF FIBREGLASS

So that you may keep your boat looking as good as new, we have made available JEANNEAU factory constituents (genuine parts and products, gel-coat of various colours) to be ordered from your stockist.

INSTRUCTIONS FOR USE

PRECAUTIONS TO OBSERVE:

For correct operation two essential factors: dry conditions, temperature between 15°C and 25°C (59°F and 77°F).

PROPORTIONS:

Our products are preactivated. You have just to add the catalyst (colourless liquid).

The usual proportion is two parts in one hundred (2%).

The pot-life (the time the product remains malleable) is approximately half an hour; hardening being complete after ten hours or so.

PROCEDURE:

To fill a dent or a scratch, clean over the surface with acetone; if necessary rubbing down beforehand.

Prepare the necessary amount of gel-coat, preferably on a pane of glass.

To apply, use a spatula or sharp instrument.

Apply a liberal coat with a view to rubbing down with a wet 'n' dry abrasive and to polishing to obtain a shiny surface.

For minor retouching to smooth surfaces, simply apply a strip of sticky tape (or better still Mylar) to the fresh gel-coat, then remove it after hardening (to obtain a shiny finish, rub down finely and buff up).

STORAGE:

So that they will keep, you should keep the constituents in a cool, dry place away from light.

Polyesters are inflammable and the necessary precautions should be taken.

BEWARE! The catalyst is a dangerous product. Keep out of the reach of children, keep clear of skin and mucous areas.

In the case of contact, wash thoroughly in soapy water and rinse well.

CLEANING:

Use acetone to clean all tools and so on.

EVER AT YOUR SERVICE

S.A. JEANNEAU

It is stipulated that this document is not contractual and that the information given herein is given merely as guidance; we reserve the right to modify the specifications of boats without prior notice and without the obligation of keeping this notice up-to-date. E60E